



WE ARE A PARTNER OF PROFESSIONALS

We operate in the field of mechanical engineering production and design of fixtures, tools and single-purpose machines.



A short history of KEAM s.r.o.

We are a team of professional engineers with over 20 years of experience in engineering and machining. Although we are a small company, thanks to a high level of expertise and quality of work, we have a growing reputation in Slovakia and abroad. This is proved by the fact that our customers are satisfied and therefore return with additional orders. Our primary goal is to deliver top quality products in the shortest time possible.

Our knowledge is

VOCATIONAL

Our equipment is

PROFESSIONAL

Our designs are

RELIABLE

Since 2007 KEAM gradually expanded its own machine workshop and in 2016 increased production capacity by a new High-Reliability and High-Performance Wire-cut Electric Discharge Machine **FANUC ROBOCUT α -C600iB**.



In November 2017 we bought a 3 axis vertical CNC milling center **HAAS VF-1 with additional 4th axis**.

At the beginning of the year 2018 was delivered a 3D measuring machine **MITUTOYO - Crysta Plus M574**.



From September 2018, we provide electro-erosive cutting on another new high-performance EDM Wire-cut **AgieCharmilles CUT E 600**.

At the beginning of the year 2019 a high-performance CNC lathe **HAAS ST-25** was delivered to us.



From 2019 grinding of larger parts is already ensured on the CNC surface grinder **BLOHM Planomat 412**.

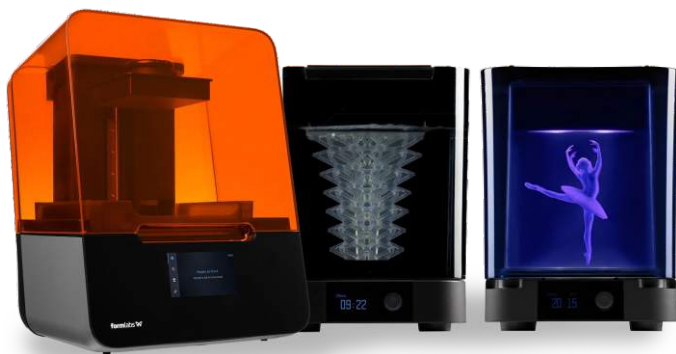

Early in November 2019 new SLA 3D printer **Formlabs Form3** arrived from the United States. From now on, the production of precision shaped parts or prototypes from different plastics will be problem-free.

In late 2019, we bought a 3D engraving machine **Sisma Laser Marker BIG SMARK 300F**. This machine innovates the industry with 3 axis marking technology to provide versatile precision engraving or deep marking parts without worrying how to secure the workpiece in place. Engineered with an additional vision system, we can have an increased functionality of engraving, marking and micro-cutting to meet the highest technical standards available.



We upgraded our machine park in 2022 and replaced our old EDM drilling machine with a brand new one. **HUBER RIVER 600**.

NEWEST ADDITIONS:

At the beginning of 2025, we launched a project to implement robots into production. For this project, we purchased a robot from ABB. The robot is smaller and is currently for training purposes, but in the future, larger ones will be applied to production.



Our workshop is equipped with modern CNC machines, which are operated by specialists with years of experience. The workshop meets the production needs of KEAM s.r.o. and of the ordered small series productions.

Workforce:

- production manager
- CNC programmer
- CNC lathes operator
- CNC milling machines operators
- EDM machines operators
- grinding machines operator (also polishing specialist)

Office:

- customer care
- material and CAD/CAM software purchasing
- experienced designer
- experienced technical-sales manager
- project managing
- robot application technology center

Machine workshop:

- 4 axis vertical CNC milling center HAAS VF-1
- 3 axis vertical CNC milling center HAAS VF-2
- 3 axis vertical CNC milling center HAAS VF-2YT
- CNC Lathe Haas TL-1
- CNC Lathe Haas ST-25
- EDM CNC AgieCharmilles Roboform 35
- EDM CNC AgieCharmilles FORM E600
- Hole Drilling EDM HUBER RIVER 600
- Wire-cut EDM FANUC ROBOCUT \square -C600iB
- Wire-cut EDM AgieCharmilles CUT E600
- CNC surface grind.m. BLOHM Planomat 412
- Surface grinding machine Jung 520
- Cylindrical grinding machine BUAJ 28
- SLA 3D printer Formlabs Form3
- Laser Marker Sisma BIG SMARK 300F
- JO-KE polishing equipment
- 3D Measuring machine MITUTOYO - Crysta Plus M574

Percent of produced parts according to customer technology usage:

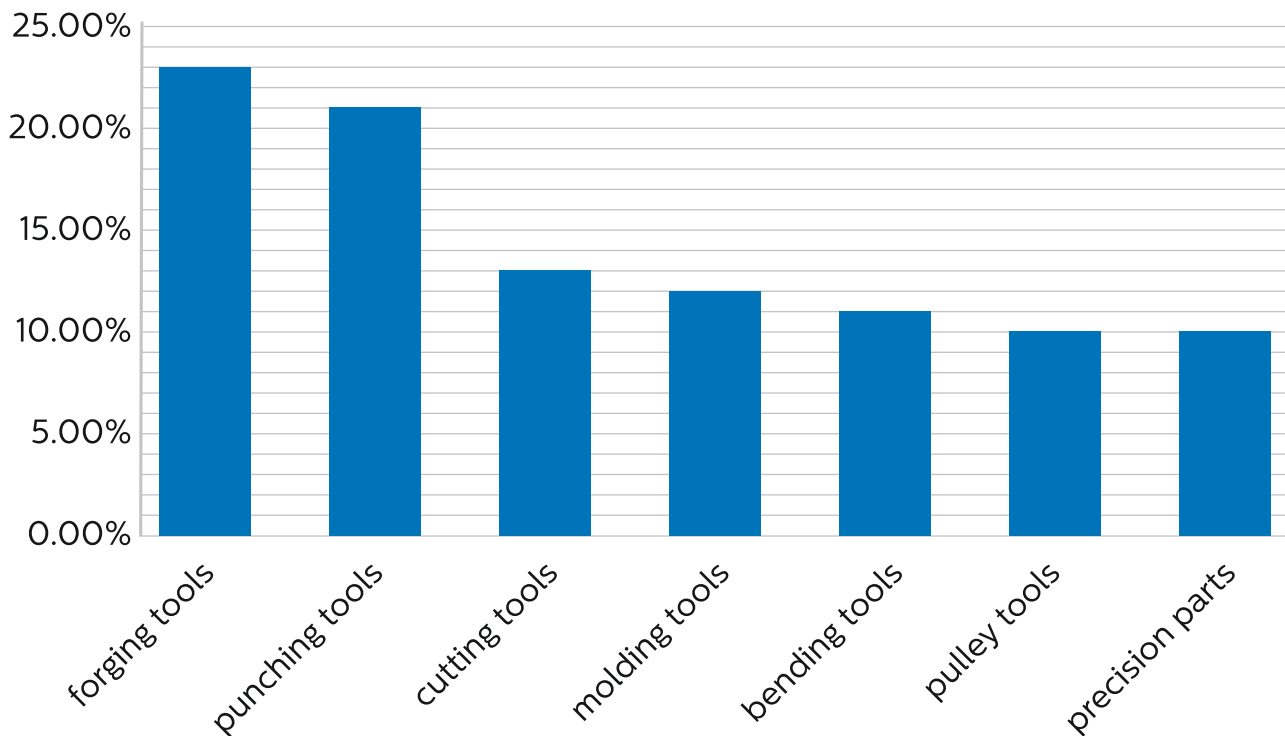

We use the following software and offer them for sale:

- ANSYS Discovery SpaceClaim (3D CAD)



SPACECLAIM
CORPORATION

- ENCY (3D CAM)



Go beyond CAD/CAM

Services:

- trainings and courses of CAD/CAM software
- maintenance and update of CAD/CAM software

Quality management – Our steps to ensure the highest quality

1. We order and use materials solely from Austria and Sweden – our suppliers are as follows:

BÖHLER UDDEHOLM

boehlerit

2. Computer Aided Design and Computer Aided Machining (CAD/CAM) – these software provide precise designs and production:

 **SPACECLAIM**
CORPORATION

Go beyond CAD/CAM

3. Simple organization, higher productivity and straightness in the company – FLOWii:

- *complete production overview and tracking*
- *full control of the production tasks*
- *with possibility to track the production of parts online, for customers as well*

 **FLOWii**

4. Ensuring highest quality heat treatment and PVD coatings of steels in the most modern factory in Eastern Europe:

voestalpine
ONE STEP AHEAD.

5. Output quality control – 3D measuring via MITUTOYO Crysta Plus M574

- *full dimensions control and comparison the produced part with the 3D model of part*
- *we can also create a 3D report on demand*



By the end of 2019, we had built and certified a quality management system in accordance with the requirements of the international standard STN EN ISO 9001:2016 and are committed to continuously improving the efficiency of its processes.

Our produced parts – forging tools

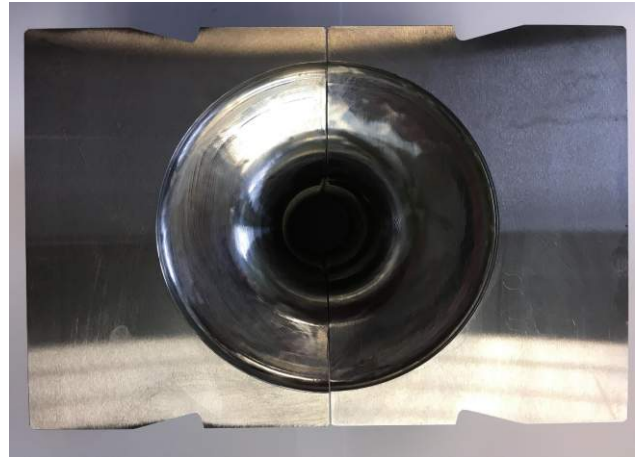

Cutting, punching and special cutting tools



Cutting tools



Punching tools



Special cutting tools

Our produced parts – Molding, pulley and bending tools

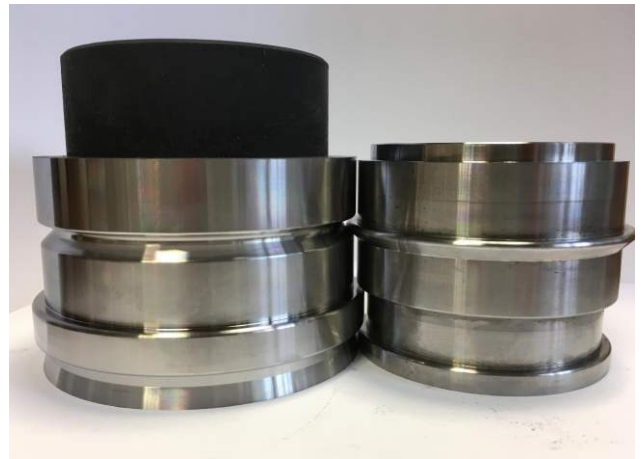

Various jaws, cutting dies



Our produced parts – Forming and pressing tools

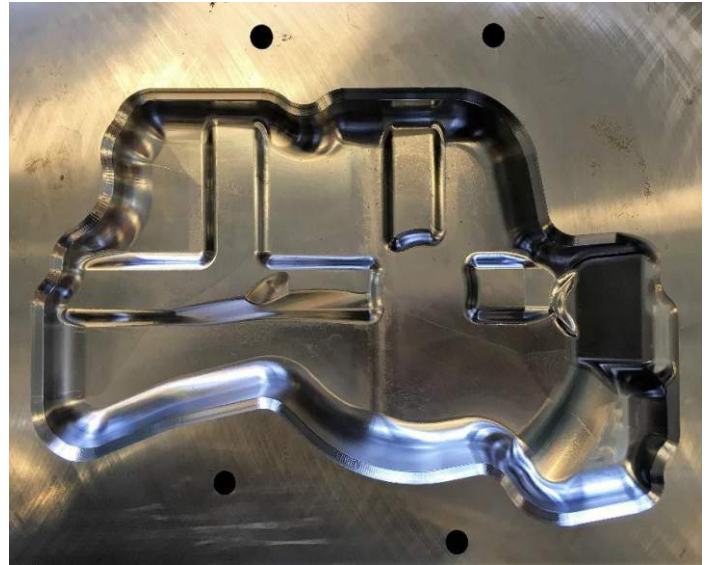
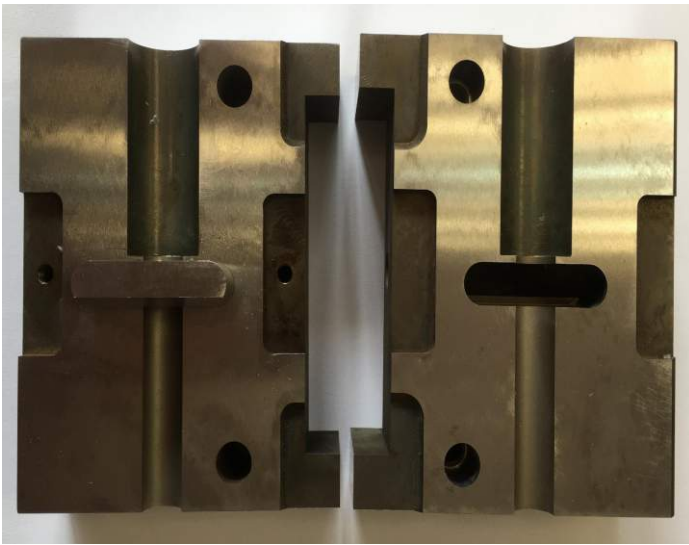

Special molding tools

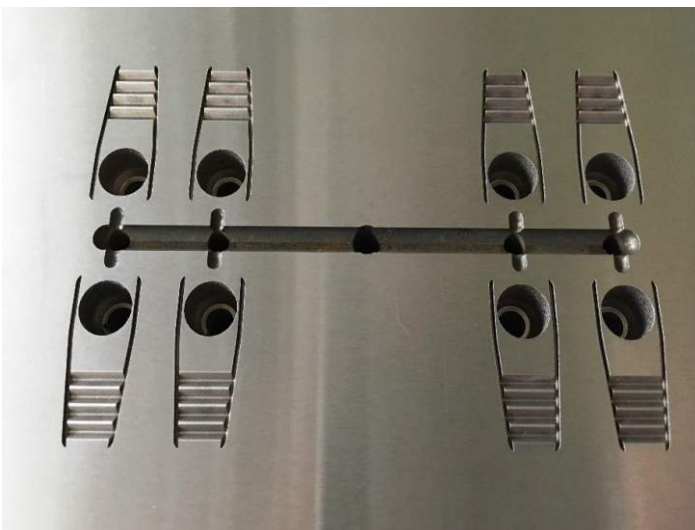

Our produced parts – Other precision tool steel parts

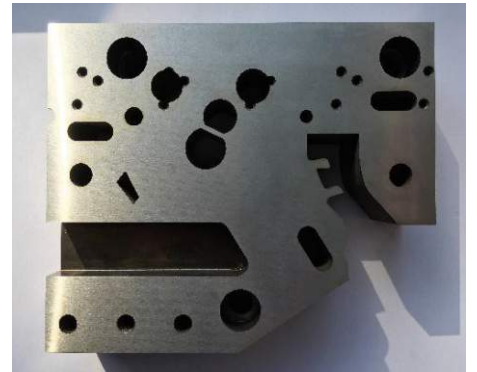
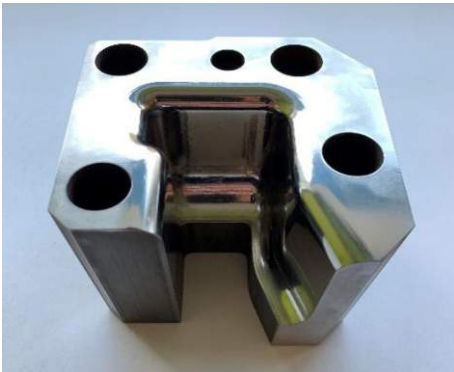
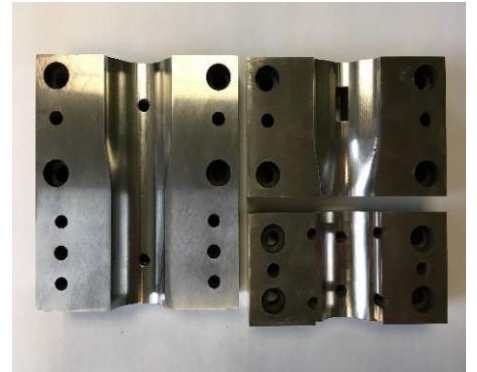
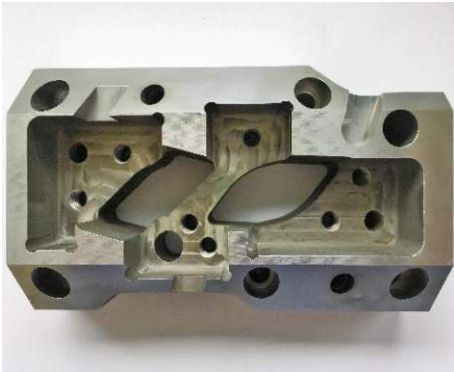
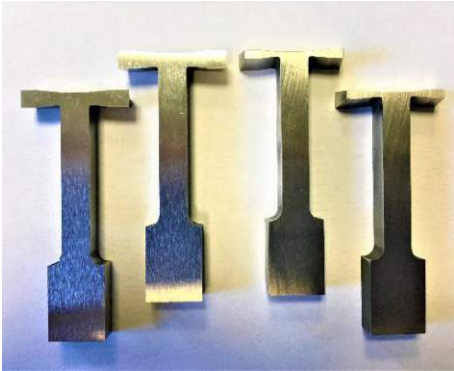
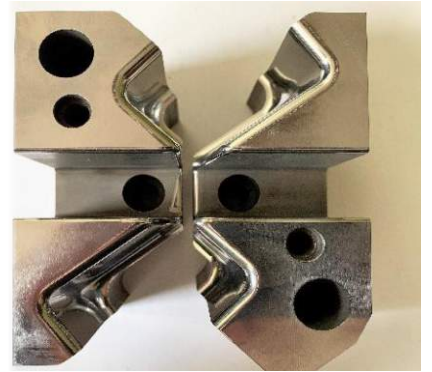
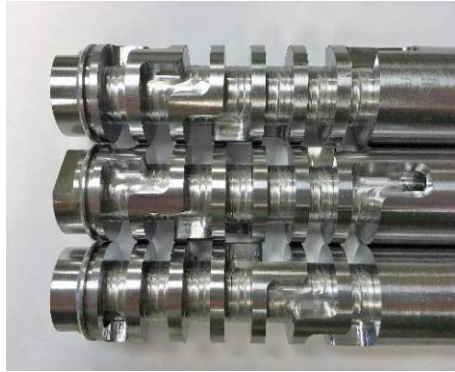

Our produced parts – Fixtures, jigs, single purpose tools, guages

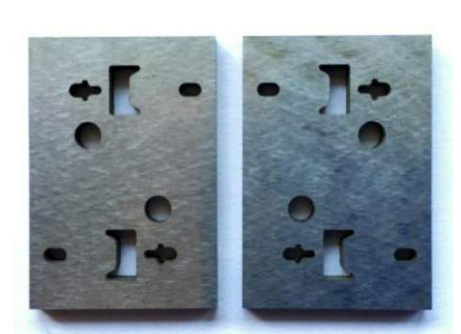
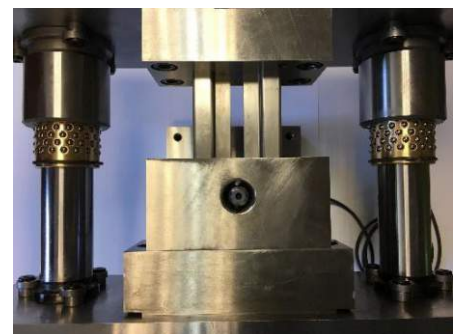
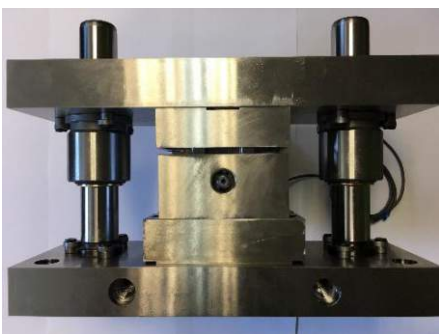
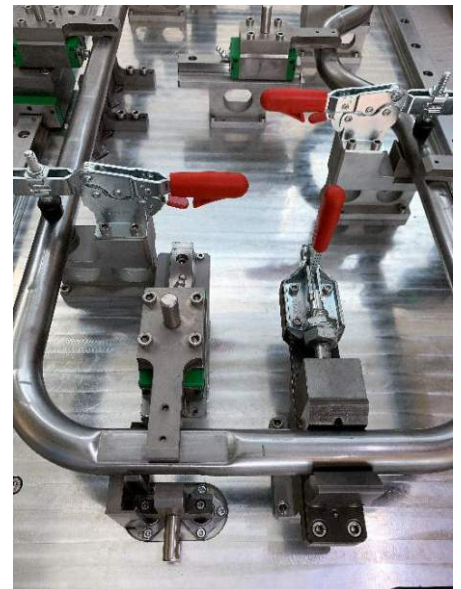
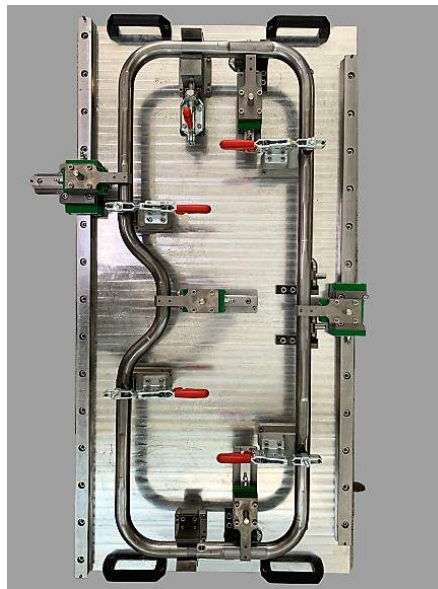
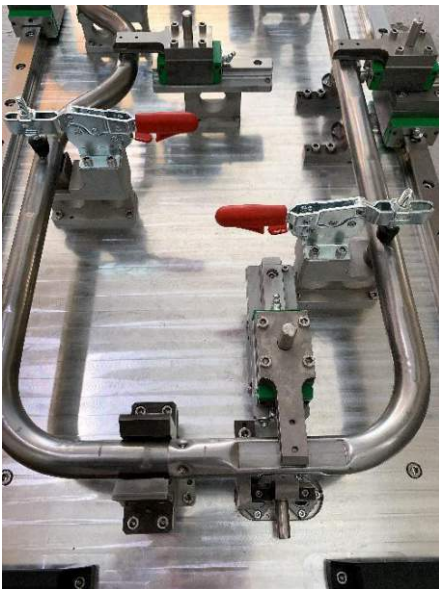
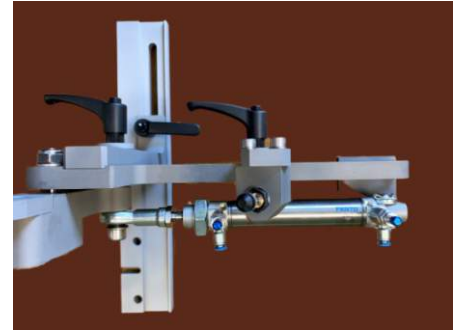

Our services – various 2D / 3D engraving (EDM sinking or laser engraving)

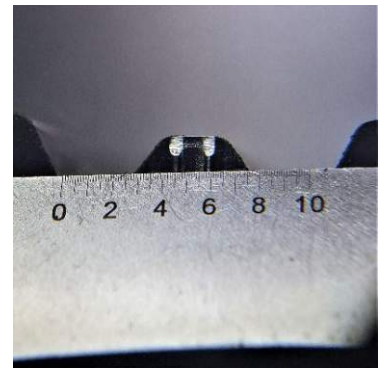
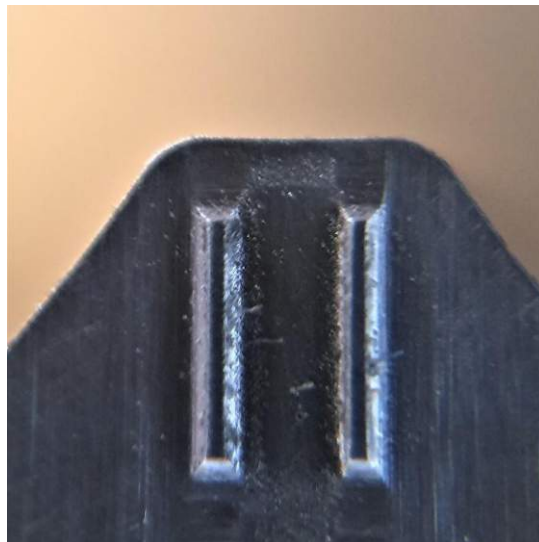
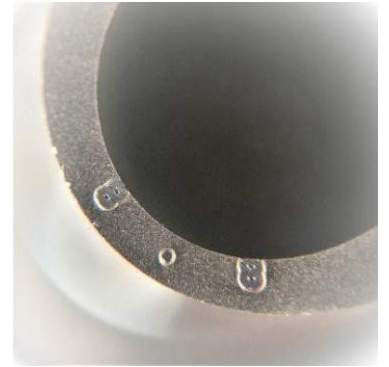
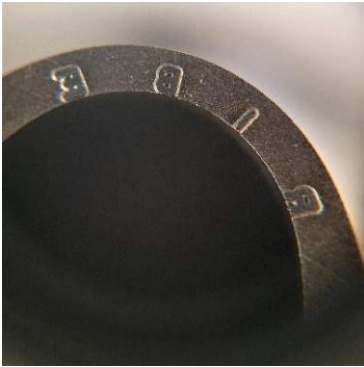

Our services – complete modifications of forging presses for semi-automatic operation (design and production of parts)

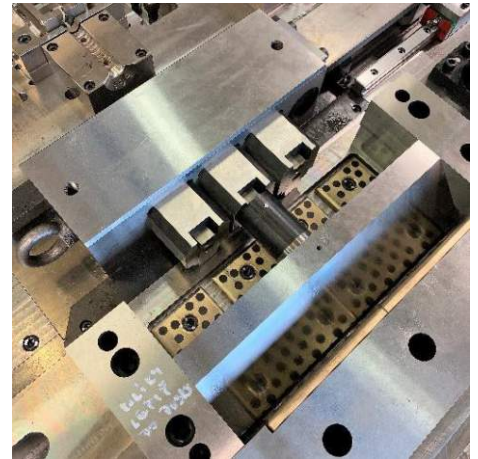
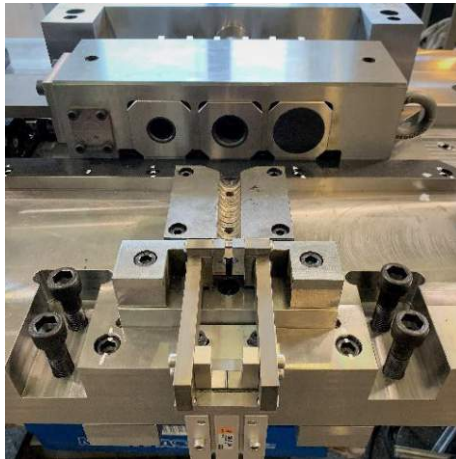
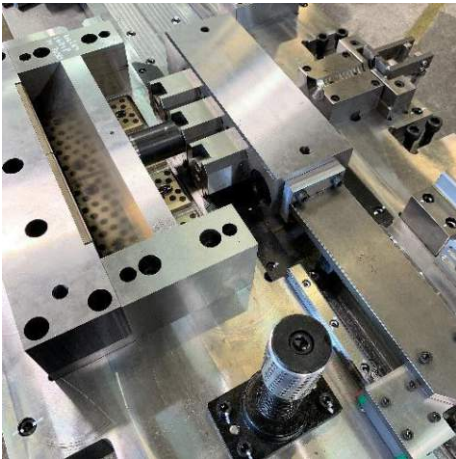
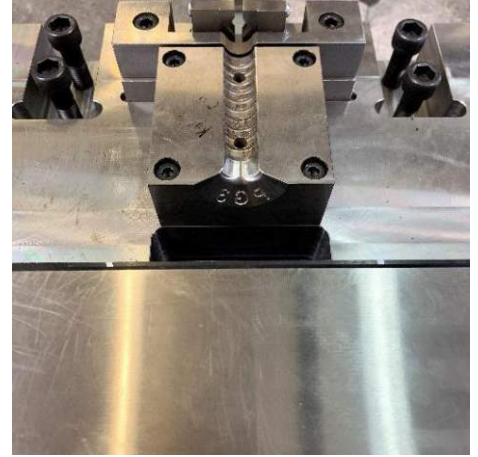
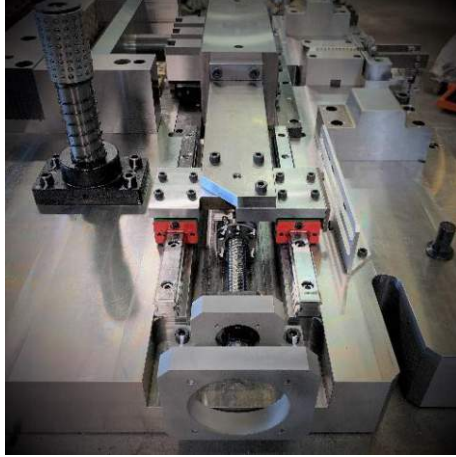
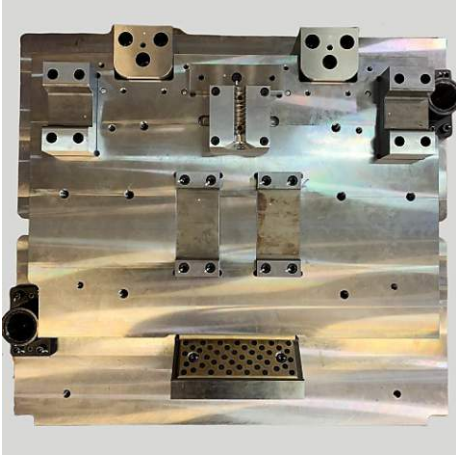

Our services – design works

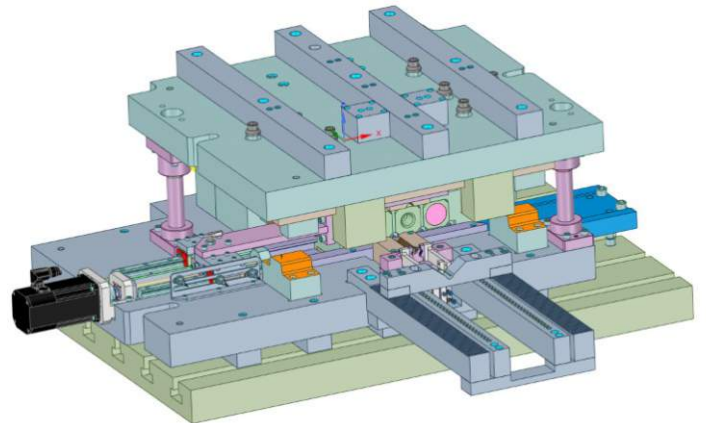
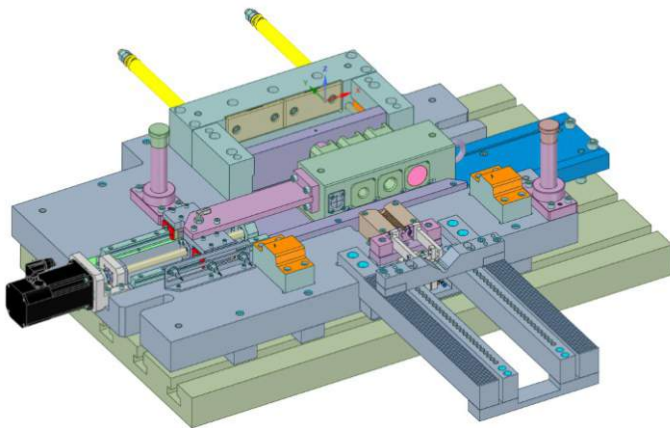
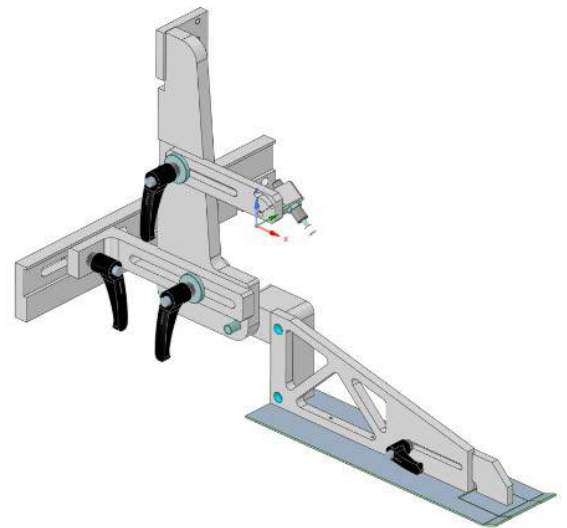
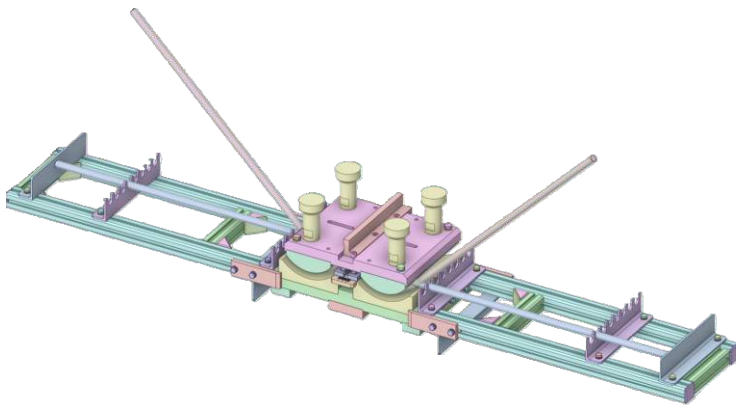
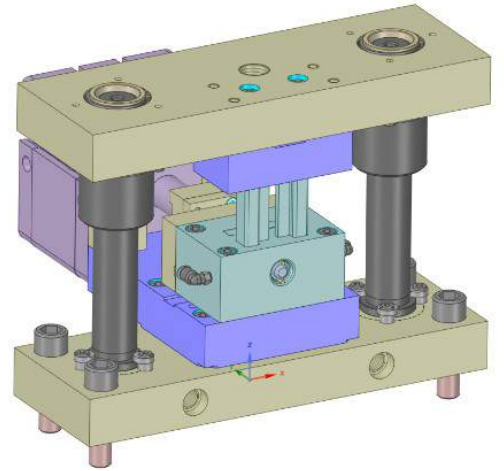
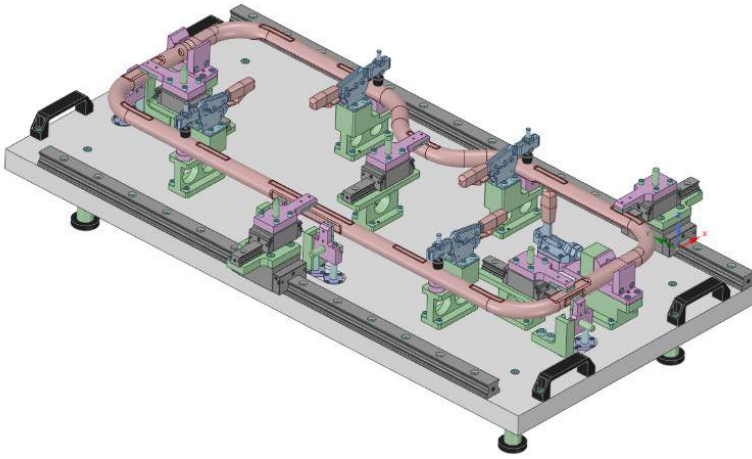

Our main customers:

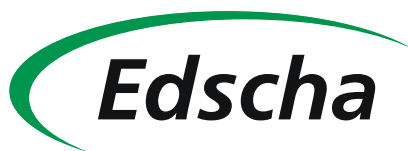

Epilogue

In 2012, we embarked on an uncharted path, starting our own production from the ground up. Today, after several years, we can confidently say we've met even the most demanding requirements. It might sound like the journey was straightforward, right? In reality, it was anything but. The path was often challenging and uneven, and we won't pretend it isn't still, or that it won't continue to be. Nevertheless, we embrace the present and look forward to the future. We extend our sincere gratitude to our customers, partners, and vendors for being part of our journey. Without them, it wouldn't have been possible, nor would it have been meaningful.

Thank you!

**We are looking forward to providing you
with very professional services.**

**For any further information or queries please
feel free to contact us:**

KEAM s.r.o.

www.keam.sk/en/

www.keam.sk/de/

Dipl. Ing. Dávid Szabó

Technical Sales Manager

Mobile: +421 907 210 244

E-mail: david.szabo@keam.sk

Dipl. Ing. Tibor Tarics

CAD/CAM and Robot Engineer

Mobile: +421 903 637 760

E-mail: tibor.tarics@keam.sk

